



TRUE FOOD SERVICE EQUIPMENT, INC.

2001 East Terra Lane • P.O. Box 970 • O'Fallon, Missouri 63366
 (636)240-2400 • Fax (636)272-2408 • (800)325-6152 • Intl Fax# (001)636-272-7546
 Parts Dept. (800)424-TRUE • Parts Dept. Fax# (636)272-9471 • www.truemfg.com

Project Name: _____

A/A #

Location: _____

Item #: _____ Qty: _____

SIS #

Model #: _____

Model:
G4SM-23RL

Glass Door Merchandiser:
Glass Four Sided Refrigerator



G4SM-23RL

- ▶ The world's #1 manufacturer of glass door merchandisers.
 - ▶ Oversized, factory balanced, refrigeration system holds 33°F to 38°F (.5°C to 3.3°C).
 - ▶ Exterior - attractive, high luster copper aluminum finish with black trim.
 - ▶ Interior - attractive, NSF approved, white aluminum interior liner with 300 series stainless steel floor.
 - ▶ Rear load design allows access into unit from two sides.
 - ▶ Doors are self closing with a positive seal, torsion type closure system.
 - ▶ "Low-E", double pane thermal insulated glass in cabinet sides and door assemblies. The latest in energy efficient technology.
 - ▶ Illuminated exterior front sign panel.
 - ▶ Entire cabinet structure is foamed-in-place using high density, CFC free, polyurethane insulation.
- Bottom mounted units feature**
- ▶ "No stoop" lower shelf to maximize product visibility.
 - ▶ Storage on top of cabinet.
 - ▶ Easily accessible condenser coil for cleaning.

ROUGH-IN DATA

Specifications subject to change without notice.
 Chart dimensions rounded up to the nearest 1/8" (millimeters rounded up to next whole number).

Model	Doors	Capacity (Cu. Ft.) (liters)	Shelves	Cabinet Dimensions (inches) (mm)			HP	Voltage	Amps	NEMA Config.	Cord Length (total ft.) (total m)	Crated Weight (lbs.) (kg)
				L	D [†]	H						
G4SM-23RL	2	23 652	4	27 1/2 699	32 1/2 826	78 5/8 1998	1/2 1/2	115/60/1 230-240/50/1	10.0 5.0	5-15P ▲	9 2.74	390 177

[†] Depth does not include 1 1/8" (29 mm) for front and 1 3/8" (35 mm) for rear door handles.

▲ Plug type varies by country.



APPROVALS:

AVAILABLE AT:

Model:
G4SM-23RL

Glass Door Merchandiser:
Glass Four Sided Refrigerator



STANDARD FEATURES

DESIGN

- True's commitment to using the highest quality materials and oversized refrigeration systems provides the user with colder product temperatures, and lower utility costs in a stylish merchandiser that creates a dynamic 360° product display.

REFRIGERATION SYSTEM

- Factory engineered, self-contained, capillary tube system using environmentally friendly (CFC free) 134A refrigerant.
- Extra large evaporator coil balanced with higher horsepower compressor and large condenser; maintains cabinet temperatures of 33°F to 38°F (.5°C to 3.3°C).
- Sealed, cast iron, self-lubricating evaporator fan motor(s) and larger fan blades give True merchandisers a more efficient low velocity, high volume airflow design. This unique design ensures more consistent, colder holding temperatures and faster recovery in high use situations.
- Bottom mounted condensing unit positioned for easy maintenance; "no stoop" lower shelf maximizes visibility by raising merchandised product to higher level.

CABINET CONSTRUCTION

- Exterior - attractive, high luster copper aluminum finish with black trim.
- Low-E, double pane thermal glass sides and door assemblies. The latest in energy efficient technology.
- Interior - attractive, NSF approved, white aluminum interior liner with 300 series stainless steel floor.
- Insulation - entire cabinet structure is foamed-in-place using high density, CFC free, polyurethane insulation.
- Welded, heavy duty galvanized frame rail dipped in rust inhibiting enamel paint for corrosion protection inside and out.

- Frame rail fitted with leg levelers.
- Illuminated exterior front sign panel. Variety of sign options available.

DOORS

- "Low-E", double pane thermal insulated glass front and rear door assemblies with extruded aluminum frames. The latest in energy efficient technology.
- Each door fitted with 12" (305 mm) long extruded aluminum handle.
- Self closing doors. Positive seal, torsion type closure system.
- Magnetic door gaskets of one piece construction, removable without tools for ease of cleaning.

SHELVING

- Four (4) adjustable, heavy duty, white PVC coated wire shelves 23⁵/₈" L x 20⁷/₈" D (601 mm x 531 mm). Four (4) chrome plated shelf clips included per shelf.
- Shelf support pilasters made of same material as cabinet interior; shelves are adjustable on 1/2" (13 mm) increments.

LIGHTING

- Front lighting system utilizes two (2) full-length, safety shielded fluorescent bulbs for enhanced, shadow-free illumination.
- Cabinet lighting utilizes electronic ballast and T-8 bulbs for brighter illumination, longer bulb life and increased energy efficiency.

MODEL FEATURES

- Evaporator is epoxy coated to eliminate the potential of corrosion.
- See our website www.truemfg.com for latest color and sign offerings.
- Convenient clean-out drain built in cabinet floor.
- Listed under NSF-7 for the storage and/or display of packaged or bottled product.

ELECTRICAL

- Unit completely pre-wired at factory and ready for final connection to a 115/60/1 phase - 15 amp dedicated outlet. Cord and plug set included.



115/60/1
NEMA-5-15R

OPTIONAL FEATURES/ACCESSORIES

Upcharge and lead times may apply.

- 230-240V / 50 Hz.
- Black exterior.
- White exterior.
- Rosewood exterior.
- Black aluminum interior liner.
- 6" (153 mm) standard legs.
- 6" (153 mm) seismic/flanged legs.
- 2 1/2" (64 mm) diameter castors.
- 4" (102 mm) diameter castors.
- Red wine thermostat.
- Chocolate thermostat.
- White wine thermostat.
- Barrel locks (factory installed).
- Black shelves.
- TrueTracIII gravity feed organizers.
- True offers five versions of the G4SM-23 with a variety of features to increase the merchandiser's function and versatility, allowing it to be customized to your needs.
- Remote cabinets (condensing units supplied by others; system comes standard with 404A expansion valve and requires R404A refrigerant). Consult factory technical service department for BTU information.

PLAN VIEW

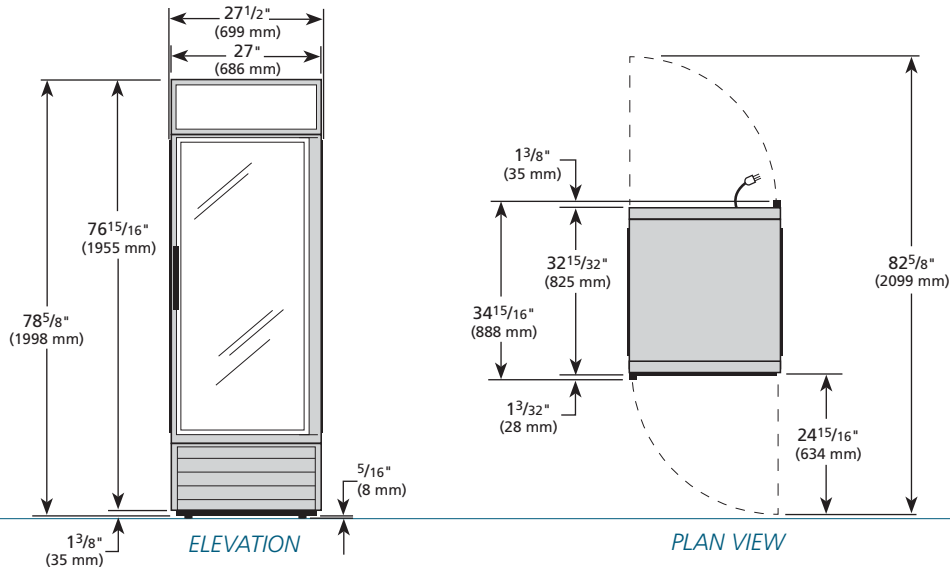

WARRANTY
 One year warranty on all parts and labor and an additional 4 year warranty on compressor. (U.S.A. only)

METRIC DIMENSIONS ROUNDED UP TO THE NEAREST WHOLE MILLIMETER
 SPECIFICATIONS SUBJECT TO CHANGE WITHOUT NOTICE



Model	Elevation	Right	Plan	3D
G4SM-23RL	TFAY10E	TFAY32S	TFA032P	TFAY323

TRUE FOOD SERVICE EQUIPMENT