



**TRUE FOOD SERVICE EQUIPMENT, INC.**

2001 East Terra Lane • P.O. Box 970 • O'Fallon, Missouri 63366  
 (636)240-2400 • Fax (636)272-2408 • (800)325-6152 • Intl Fax# (001)636-272-7546  
 Parts Dept. (800)424-TRUE • Parts Dept. Fax# (636)272-9471 • www.truemfg.com

Project Name: \_\_\_\_\_

A/A #

Location: \_\_\_\_\_

Item #: \_\_\_\_\_ Qty: \_\_\_\_\_

SIS #

Model #: \_\_\_\_\_

Model:  
**G4SM-23-PT**

**Glass Door Merchandiser:**  
*Pass-Thru Glass Four Sided Refrigerator*



**G4SM-23-PT**

- ▶ The world's #1 manufacturer of glass door merchandisers.
  - ▶ Oversized, factory balanced, refrigeration system holds 33°F to 38°F (.5°C to 3.3°C).
  - ▶ Exterior - attractive, high luster copper aluminum finish with black trim.
  - ▶ Interior - attractive, NSF approved, white aluminum interior liner with 300 series stainless steel floor.
  - ▶ Pass-thru design allows access into unit from two sides.
  - ▶ Doors are self closing with a positive seal, torsion type closure system.
  - ▶ "Low-E", double pane thermal insulated glass in door assemblies and sides. The latest in energy efficient technology.
  - ▶ Illuminated exterior front and rear sign panels.
  - ▶ Entire cabinet structure is foamed-in-place using high density, CFC free, polyurethane insulation.
- Bottom mounted units feature**
- ▶ "No stoop" lower shelf to maximize product visibility.
  - ▶ Storage on top of cabinet.
  - ▶ Easily accessible condenser coil for cleaning.

**ROUGH-IN DATA**

Specifications subject to change without notice.  
 Chart dimensions rounded up to the nearest 1/8" (millimeters rounded up to next whole number).

Model	Doors	Capacity (Cu. Ft.) (liters)	Shelves	Cabinet Dimensions (inches) (mm)			HP	Voltage	Amps	NEMA Config.	Cord Length (total ft.) (total m)	Crated Weight (lbs.) (kg)
				L	D <sup>†</sup>	H						
G4SM-23-PT	2	23 652	4	27 1/2 699	32 3/4 832	78 5/8 1998	1/2 1/2	115/60/1 230-240/50/1	10.0 5.0	5-15P ▲	9 2.74	375 171

† Depth does not include 1 1/8" (29 mm) each side for door handles.

▲ Plug type varies by country.



APPROVALS:

AVAILABLE AT:

Model:

**G4SM-23-PT**

# Glass Door Merchandiser: Pass-Thru Glass Four Sided Refrigerator



## STANDARD FEATURES

### DESIGN

- True's commitment to using the highest quality materials and oversized refrigeration systems provides the user with colder product temperatures, and lower utility costs in a stylish merchandiser that creates a dynamic 360° product display.

### REFRIGERATION SYSTEM

- Factory engineered, self-contained, capillary tube system using environmentally friendly (CFC free) 134A refrigerant.
- Extra large evaporator coil balanced with higher horsepower compressor and large condenser; maintains cabinet temperatures of 33°F to 38°F (.5°C to 3.3°C).
- Sealed, cast iron, self-lubricating evaporator fan motor(s) and larger fan blades give True merchandisers a more efficient low velocity, high volume airflow design. This unique design ensures more consistent, colder holding temperatures and faster recovery in high use situations.
- Bottom mounted condensing unit positioned for easy maintenance; "no stoop" lower shelf maximizes visibility by raising merchandised product to higher level.

### CABINET CONSTRUCTION

- Exterior - attractive, high luster copper aluminum finish with black trim.
- Glass sides - Low-E, double pane thermal glass end assemblies. The latest in energy efficient technology.
- Interior - attractive, NSF approved, white aluminum interior liner with 300 series stainless steel floor.
- Insulation - entire cabinet structure is foamed-in-place using high density, CFC free, polyurethane insulation.
- Welded, heavy duty galvanized frame rail dipped in rust inhibiting enamel paint for corrosion protection inside and out.

- Frame rail fitted with leg levelers.
- Illuminated exterior front and rear sign panels. Variety of sign options available.

### DOORS

- "Low-E", double pane thermal glass front and rear door assemblies with extruded aluminum frames. The latest in energy efficient technology.
- Each door fitted with 12" (305 mm) long extruded aluminum handle.
- Self closing doors. Positive seal, torsion type closure system.
- Magnetic door gaskets of one piece construction, removable without tools for ease of cleaning.
- Door locks standard.

### SHELVING

- Four (4) adjustable, heavy duty, white PVC coated wire shelves 22<sup>7</sup>/<sub>8</sub>" L x 21<sup>3</sup>/<sub>4</sub>" D (582 mm x 553 mm). Four (4) chrome plated shelf clips included per shelf.
- Shelf support pilasters made of same material as cabinet interior; shelves are adjustable on 1/2" (13 mm) increments.

### LIGHTING

- Front and rear lighting system utilizes two (2) full-length, safety shielded fluorescent bulbs for enhanced, shadow-free illumination.
- Cabinet lighting utilizes electronic ballast and T-8 bulbs for brighter illumination, longer bulb life and increased energy efficiency.

### MODEL FEATURES

- Evaporator is epoxy coated to eliminate the potential of corrosion.
- See our website [www.truemfg.com](http://www.truemfg.com) for latest color and sign offerings.
- Listed under NSF-7 for the storage and/or display of packaged or bottled product.

### ELECTRICAL

- Unit completely pre-wired at factory and ready for final connection to a 115/60/1 phase, 15 amp dedicated outlet. Cord and plug set included.



115/60/1  
NEMA-5-15R

### OPTIONAL FEATURES/ACCESSORIES

Upcharge and lead times may apply.

- 230-240V / 50 Hz.
- Black exterior.
- White exterior.
- Rosewood exterior.
- Black aluminum interior liner.
- 6" (153 mm) standard legs.
- 6" (153 mm) seismic/flanged legs.
- 2<sup>1</sup>/<sub>2</sub>" (64 mm) diameter castors.
- 4" (102 mm) diameter castors.
- Red wine thermostat.
- Chocolate thermostat.
- White wine thermostat.
- Novelty baskets.
- Black shelves.
- True offers five versions of the G4SM-23 with a variety of features to increase the merchandiser's function and versatility, allowing it to be customized to your needs.
- Remote cabinets (condensing units supplied by others; system comes standard with 404A expansion valve and requires R404A refrigerant). Consult factory technical service department for BTU information.

## PLAN VIEW

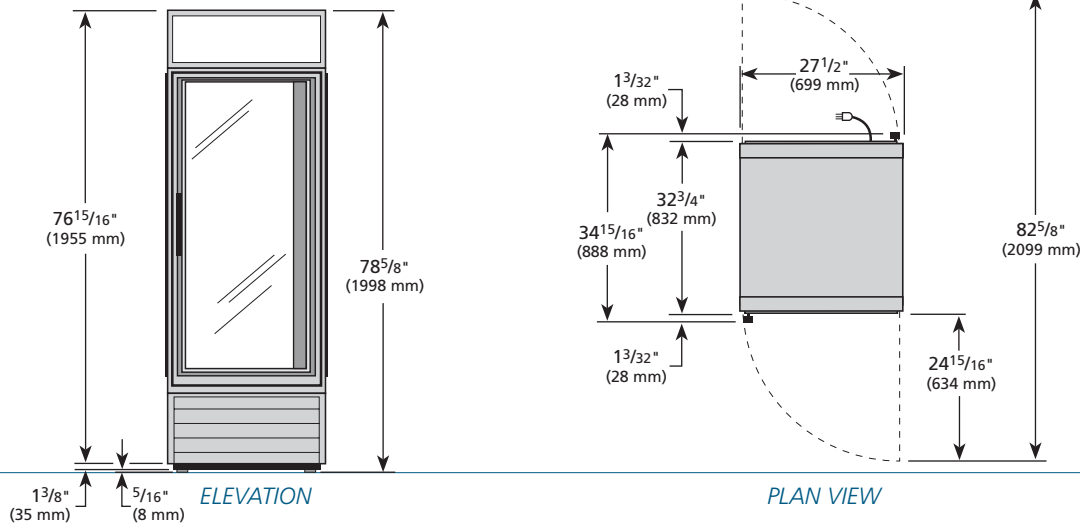

### WARRANTY

One year warranty on all parts and labor and an additional 4 year warranty on compressor. (U.S.A. only)

METRIC DIMENSIONS ROUNDED UP TO THE NEAREST WHOLE MILLIMETER  
SPECIFICATIONS SUBJECT TO CHANGE WITHOUT NOTICE



Model	Elevation	Right	Plan	3D
G4SM-23-PT	TFAY10E	TFAY34S	TFA034P	TFAY343

## TRUE FOOD SERVICE EQUIPMENT