

KD SERIES

GLASS DISPLAY MERCHANDISER

Item # _____

Project: _____

Qty: _____
 *AutoCad available on KCL

KD SERIES
4/08
Item # 13026

DIMENSIONS
W x D x H

KD-90D
 35.4 x 15.4 x 29.1



KD-90D
 Air-Cooled
 Shown

- Appealing, sanitary design
- Eye-catching point of sale merchandiser
- Sliding glass doors are easily removed to clean unit
- Compact rotary compressor provides quiet operation
- Brilliant non-glare fluorescent fixture highlights food
- Removable, cleanable air filter for more efficient operation and dependable performance
- Space saver construction with heavy duty plate glass on four sides
- Two adjustable glass shelves for flexibility and maximum space utilization
- R-134A Refrigerant

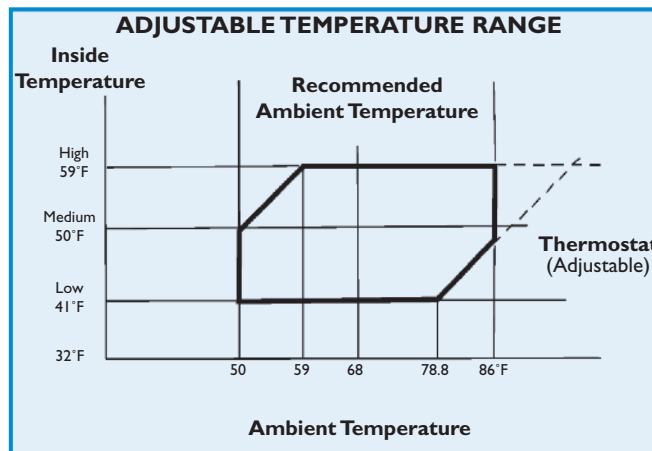

Warranty

Warranty valid in United States, Canada, Puerto Rico, & U.S. Territories. Contact factory for warranty in other countries.

One Year - Parts & Labor on entire unit.

Two Year - Parts & Labor on compressor, evaporator, air-cooled condenser.

Five Year - Parts on: Compressor; Air-cooled condenser.



Hoshizaki

KD SERIES GLASS DISPLAY MERCHANDISER

KD-90D • Counter top display case

SPECIFICATIONS

Model	Condenser	Storage Cubic Feet	Shelf Space Square Feet	Shipping Weight
KD-90D	Air-Cooled	4.2	6.6	145 lbs.

*Refrigerated Display Case - Not for overnight storage

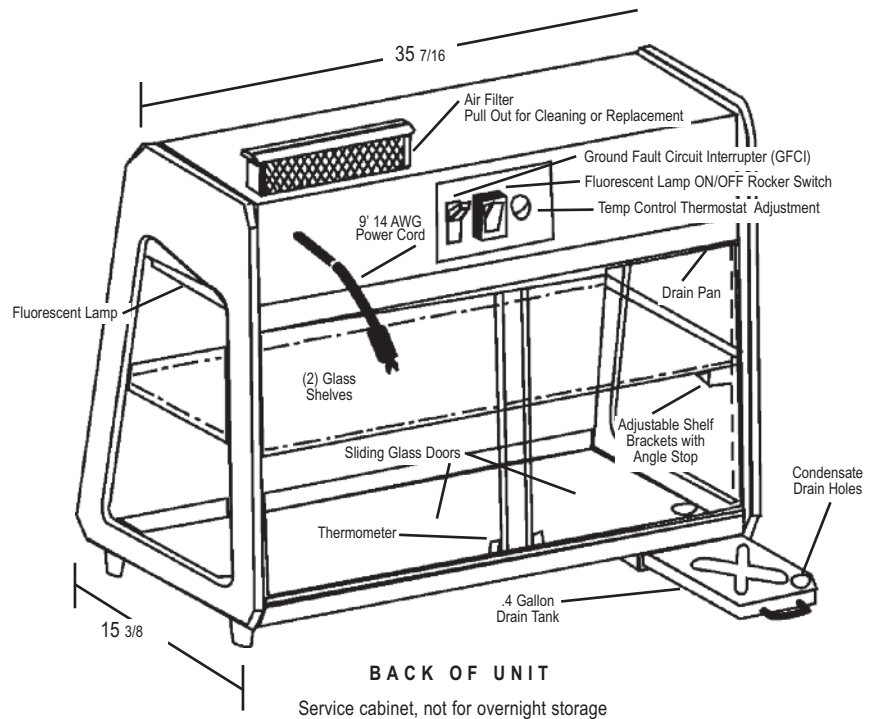
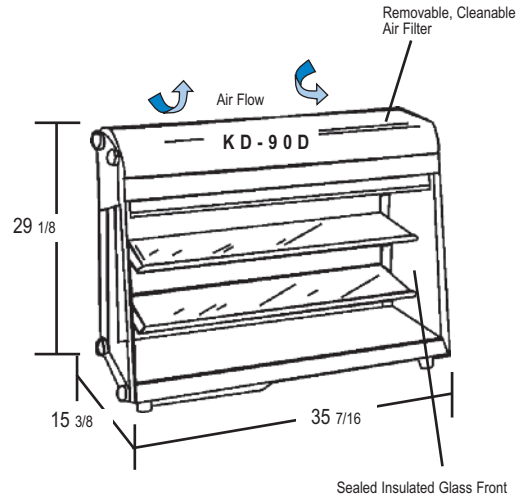

ELECTRICAL/KD SERIES

• 115V/60/1

OPERATING LIMITS

- Ambient Temp Range 50 - 80°F
- Voltage Range 104 - 126V
- Adjustable Temp Range 46 - 60°F

SERVICE

- Removable/cleanable air filters



© HOSHIZAKI AMERICA, INC.

618 Hwy. 74 S., Peachtree City, GA 30269

TEL 1-800-438-6087

FAX 1-800-345-1325

www.hoshizaki.com

Printed in U.S.A.

