

Item # \_\_\_\_\_

Project: \_\_\_\_\_

Qty: \_\_\_\_\_

\*AutoCad available on KCL

# F-300/500BAF

## SELF-CONTAINED FLAKER WITH BUILT-IN STORAGE

F-300/500BAF

4/08

Item # 13142

### FLAKER DIMENSIONS

W x D x H

#### F-300BAF

36 x 24 x 39\*

\*with 6" legs

#### F-500BAF

38 x 29 x 42\*

\*with 6" legs

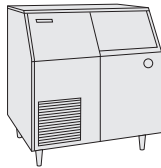

F-300BAF

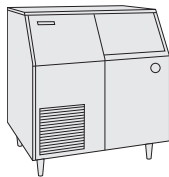

F-500BAF

### F-300BAF

Air-Cooled

### F-500BAF

Air-Cooled  
Shown



### F-300BAF

- Up to 303 lbs. of ice production per 24 hours
- Up to 110 lbs. built-in storage

### F-500BAF

- Up to 478 lbs. of ice production per 24 hours
- Up to 250 lbs. built-in storage

### F-300BAF & F-500BAF

- Designed for long life dependability
- Corrosion resistant stainless steel
- Automatic system flush when bin control is activated
- Gear motor protected from overload
- Removable air filter
- R-404A Refrigerant
- Scoop - Protected by *HoshiGuard* Antimicrobial Agent



### Warranty

Valid in United States, Canada, Puerto Rico, & U.S. Territories. Contact factory for warranty in other countries.

**Two Year** - Parts & Labor on entire unit.

**Five Year** - Parts on: Compressor, air-cooled condenser coil.



# HOSHIZAKI

## SELF-CONTAINED FLAKER WITH BUILT-IN STORAGE BIN

### DIMENSIONS

W x D x H

**F-300BAF**  
36 x 24 x 39"

**F-500BAF**  
38 x 29 x 42"  
\*with 6" legs

- Air-cooled
- Air-cooled

### F-300BAF / AIR-COOLED

Water Temp ° F.	50°	70°	90°	
Air Temp ° F.	70°	303	290	278
	80°	267	256	246
	90°	236	232	218

### F-500BAF / AIR-COOLED

Water Temp ° F.	50°	70°	90°	
Air Temp ° F.	70°	478	458	438
	80°	419	400	383
	90°	366	359	335

### UTILITY CONSUMPTION

Model Number	Approximate Electric		KWH per 100 LBS.	
	90/70	70/50	90/70	70/50
F-300BAF	651W	613W	6.7	4.8
F-500BAF	900W	854W	6.0	4.3

### SPECIFICATIONS

Model Number	Condenser	Amperage	Min. Circuit Ampacity	Shipping Weight
F-300BAF	Air-Cooled	9.0	N/A	210 lbs.
F-500BAF	Air-Cooled	10.4	20	270 lbs.

### STORAGE BINS

Model Number	Application Capacity
F-300BAF	Built-in 110 lb. capacity
F-500BAF	Built-in 250 lb. capacity

- Circuit breaker or fuse protects gear motor from overload.
- Gear motor runs one minute after termination of ice making to clear all ice from evaporator.

**\*F-500 does not include power cord**

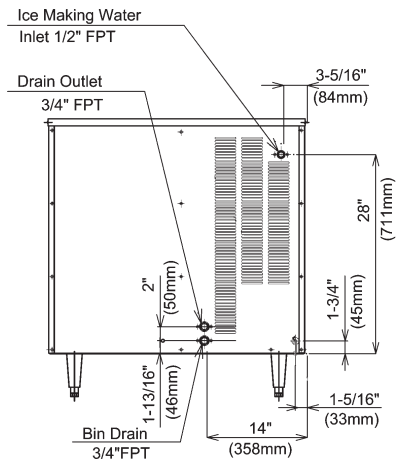
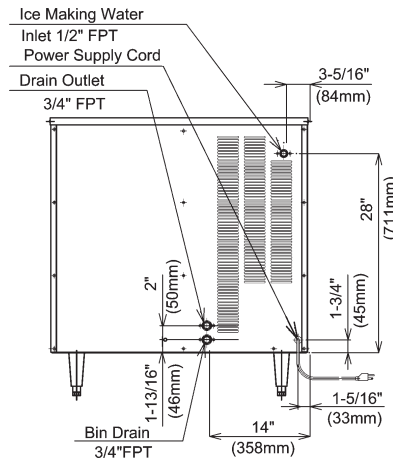
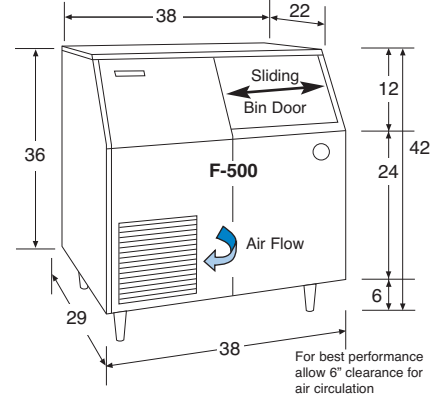
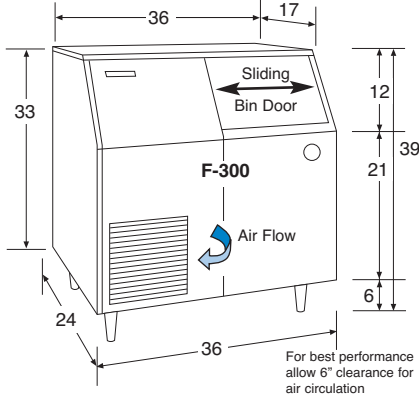

F-300 / BACK VIEW

F-500 / BACK VIEW

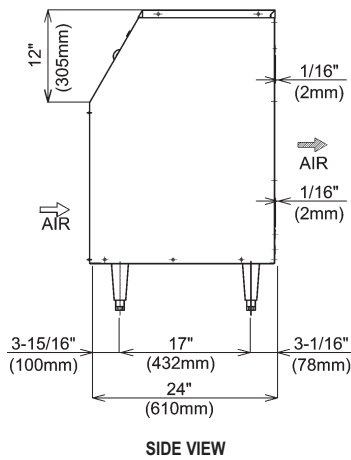

SIDE VIEW

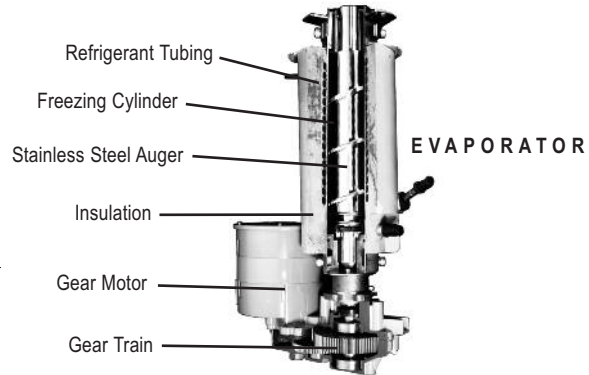

EVAPORATOR

### ELECTRICAL & PLUMBING/F-300/500BAF

- 115V/60/1
- 15 amp Max Fuse Size - F-300BAF
- 20 amp Max Fuse Size - F-500BAF
- 3/8" OD copper or equivalent independent potable water supply
- 3/4" FPT independent drain connection



© HOSHIZAKI AMERICA, INC.

### OPERATING LIMITS

- Ambient Temp Range 45 - 100°F
- Water Temp Range 45 - 90°F
- Water Pressure 10 - 113psig
- Voltage Range 104 - 127V

### SERVICE

- Panels easily removed and all components accessible for service.
- Removable/cleanable air filters

