

AM-50BAE-(AD)DS

Item # _____

Project: _____

Qty: _____

*AutoCad available on KCL

SELF-CONTAINED CUBER WITH BUILT-IN STORAGE BIN (ADA Compliant with Customized Door System)

AM-50BAE-DS

4/08

Item # 13172

CUBER DIMENSIONS W x D x H

AM-50BAE-DS
14^{7/8} x 22^{5/8} x 33^{1/2}

AM-50BAE-ADDS
14^{7/8} x 22^{5/8} x 31^{1/2}

*Designed to accommodate custom cabinetry to affix to stainless door.

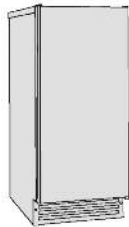

AM-50BAE-DS

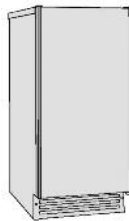

AM-50BAE-(AD)DS

AM-50BAE-DS*

Air-Cooled
Shown
with Custom Cabinetry

AM-50BAE-ADDS*

Air-Cooled
ADA Compliant Unit



*Customer responsible for providing cabinetry

AM-50BAE-DS

- Undercounter design is less than 34 inches tall

AM-50BAE-ADDS

- Undercounter design is less than 32 inches tall, which complies with the Americans with Disabilities Act (ADA)

AM-50BAE-DS & AM-50BAE-ADDS

- Up to 55 lbs. of ice production per 24 hours
- UL approval for outdoor use
- Up to 22 lbs. of built-in storage capacity
- Power switch accessible without panel removal
- Easily disassembled water circuit for easy cleaning
- Front in, front out airflow
- Fewer moving parts for longer life
- Swing style reversible door
- Side trim kit available
- Optional drain pump HS-0190
- R-134A Refrigerant



Warranty

Valid in United States, Canada, Puerto Rico, & U.S. Territories. Contact factory for warranty in other countries.

Two Year - Parts & Labor on entire machine.



AM-50BAE-(AD)DS* SELF-CONTAINED CUBER WITH BUILT-IN STORAGE BIN

*Designed to accommodate custom cabinetry to affix to stainless door.

DIMENSIONS

W x D x H

AM-50BAE-DS
14^{7/8} x 22^{5/8} x 33^{1/2}

AM-50BAE-ADDS
14^{7/8} x 22^{5/8} x 31^{1/2}

- Air-cooled
- Air-cooled, ADA compliant

AIR-COOLED

| | |
|----------------|---------|
| Water Temp° F. | 50° |
| Air Temp° F. | 70° |
| | 55 lbs. |

UTILITY CONSUMPTION (AIR 70°F/WATER 50°F)

| Model Number | Ice Production Per Cycle Lbs. Cubes | KWH per 100 LBS. | Potable Water Gal. per 100 lbs. | Condenser Water Gal. per 100 lbs. |
|-----------------|--|------------------|---------------------------------|-----------------------------------|
| AM-50BAE-(AD)DS | 0.65 24 | 9.9 | 53.7 | N/A |

SPECIFICATIONS

| Model Number | Condenser | Amperage | Min. Circuit Ampacity | Shipping Weight |
|-----------------|------------|----------|-----------------------|-----------------|
| AM-50BAE-(AD)DS | Air-Cooled | 3.4 | 15 | 115 lbs.* |

* Without pallet

AM CUBE DIMENSIONS

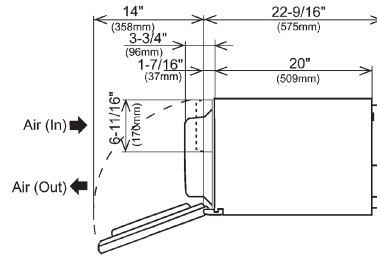
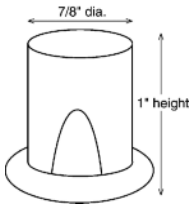

TOP DIMENSIONS

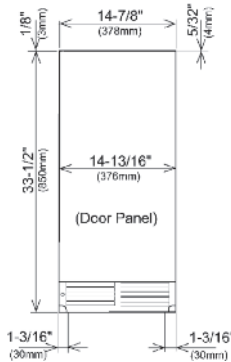

FRONT DIMENSIONS

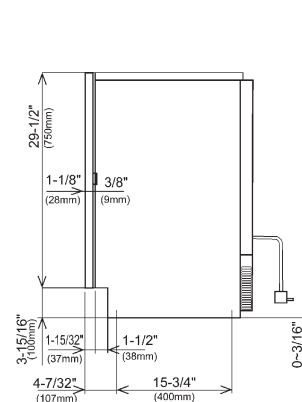

SIDE DIMENSIONS

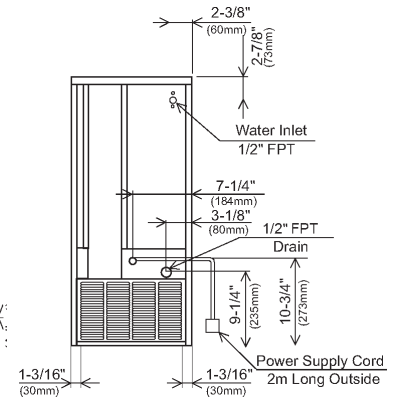

BACK DIMENSIONS

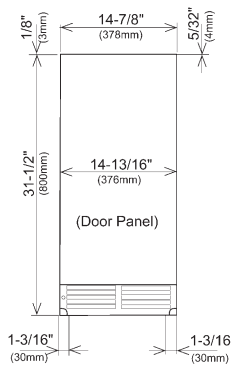

FRONT DIMENSIONS
(ADA compliant unit)

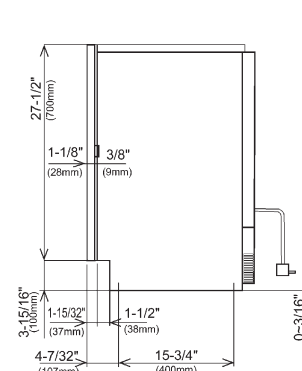

SIDE DIMENSIONS
(ADA compliant unit)

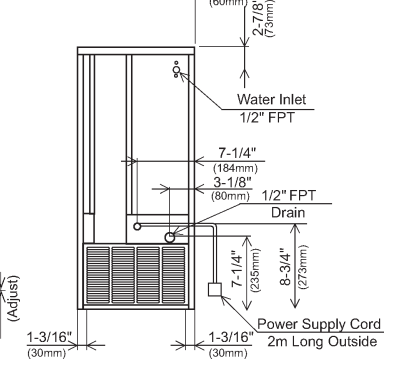

BACK DIMENSIONS
(ADA compliant unit)

ELECTRICAL & PLUMBING

- 115V/60/1ø
- 15 amp Max Fuse
- 1/2" FPT Water Inlet
- 1/2" FPT Drain

OPERATING LIMITS

- Ambient Temp Range 45 - 100°F
- Water Temp Range 45 - 95°F
- Water Pressure 7 - 113psig
- Voltage Range 104 - 127V

OPTIONS

- Side trim kit available



© HOSHIZAKI AMERICA, INC.

618 Hwy. 74 S., Peachtree City, GA 30269

TEL 1-800-438-6087

FAX 1-800-345-1325

www.hoshizaki.com

Printed in U.S.A.

